

FITTING INSTRUCTION

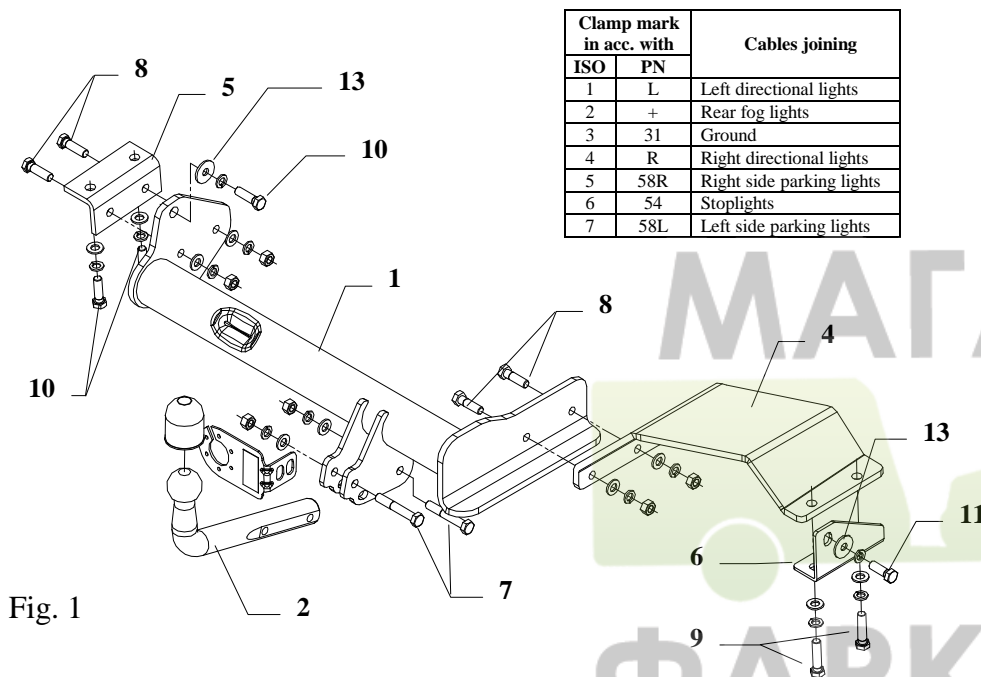

Clamp mark in acc. with		Cables joining
ISO	PN	
1	L	Left directional lights
2	+	Rear fog lights
3	31	Ground
4	R	Right directional lights
5	58R	Right side parking lights
6	54	Stoplights
7	58L	Left side parking lights

Fig. 1

This towbar is designed to assembly in following car: **TOYOTA PREVIA**, produced since 06.2000, cat. no. **O60** and is prepared to tow trailers max total weight **1600 kg** and max vertical load **75 kg**.

From manufacturer

Thank you for buying our product. Their reliability has been confirmed in many tests. Reliability of towbar depends also on correct assembly and right operation. For this reasons we kindly ask to read carefully this instruction and apply to hints.

The towbar should be install in points described by a car producer.

Torque settings for nuts and bolts (8,8):

M 8	25 Nm	M 10	55 Nm
M 12	85 Nm	M 14	135 Nm

Fitting instructions

1. Take out spare wheel – remove plug and unscrew bolt fastening wheel cover.
2. Unscrew original tow handles (not used any more).
3. Take off the muffler from last, rubber handles and unscrew thermal shield.
4. Cut out fragments of thermal shield in accordance with fig. 2. Reassemble it.
5. In places of original tow handles screw on the left side element pos. 5 using bolts M12x1,25x40mm pos. 10 and on the right side elements pos. 4 and 6 screw in accordance with fig. 1 – from below use bolts M12x1,25x50 (pos. 9) and from side to the chassis member use bolt M12x1,25x35mm (pos. 11).
6. Put main bar (pos. 1) between fixed elements (see fig. 1) and screw it using bolts M12x 40mm and M12x1,25x40mm (pos. 8 and 10)
7. Install the muffler on his handles.
8. Screw tow-ball (pos. 2) and socket plate (pos. 3) using bolts M12x75mm (pos. 7) from equipment.
9. Tighten all bolts according to the torque shown in the table.
10. Reassemble spare wheel unit..
11. Connect electric wires of 7-pole socket according to the instruction of the car. (Recommend to make at authorized service station)
12. Complete paint layer damaged during installation.

Fig. 2

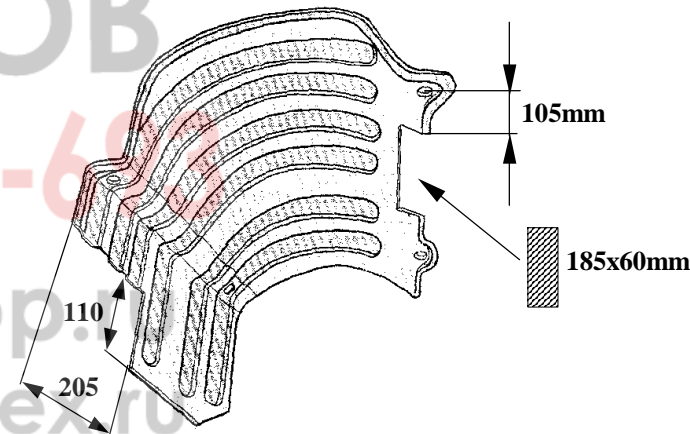











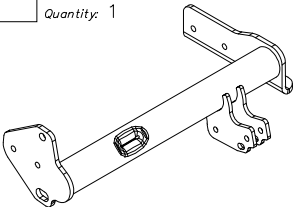
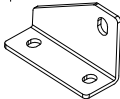

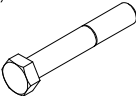
NOTE

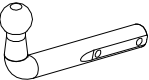
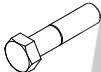
After install the towbar you should get adequate note in registration book (at authorised service station).The car should be equipped with:

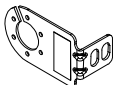
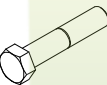
- Indicators
- Tow mirrors

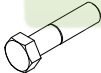
After 1000km check all bolts and nuts. The ball of towbar must be always kept clear and conserve with a grease.

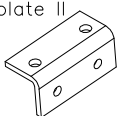
Towbar equipment:

Pos. 1 Name: Main bar Quantity: 1 	Pos. 6 Name: Bending plate III Quantity: 1 	Pos. 12 Name: Nut 8 B Quantity: 6 Dim.: M12 
	Pos. 7 Name: Bolt 8,8 B Quantity: 2 Dim.: M12x75mm 	Pos. 13 Name: Washer Quantity: 2 Dim.: Ø35xØ13x3mm 
Pos. 2 Name: Ball Quantity: 1 	Pos. 8 Name: Bolt 8,8 B Quantity: 2 Dim.: M12x40 	Pos. 14 Name: Washer Quantity: 10 Dim.: Ø 13 mm 
Pos. 3 Name: Socket plate Quantity: 1 	Pos. 9 Name: Bolt 8,8 A Quantity: 2 Dim.: M12x1.25x50 	Pos. 15 Name: Spring washer Quantity: 12 Dim.: Ø 12,2 mm 
Pos. 4 Name: Bending plate Quantity: 1 	Pos. 10 Name: Bolt 8,8 A Quantity: 5 Dim.: M12x1.25x40 	Pos. 16 Name: Ball cover Quantity: 1 
Pos. 5 Name: Bending plate II Quantity: 1 	Pos. 11 Name: Bolt 8,8 A Quantity: 1 Dim.: M12x1.25x30 	



PPUH AUTO-HAK S.J.
 Produkcja Haków Holowniczych
 Henryk & Zbigniew Nejman
 76-200 SŁUPSK ul. Słoneczna 16K
 tel/fax (059) 8-414-414; 8-414-413
 E-mail: office@autohak.com.pl
 www. autohak.com.pl

Towing hitch (without electrical set)

Class: A50-X Cat. no. O 60

Designed for:

Manufacturer: **TOYOTA**

Model: **PREVIA**

produced since 06.2000

Technical data:

D-value: **10,1 kN**

maximum trailer weight: **1600 kg**

maximum vertical cup load: **75 kg**

Approval number acc. to regulations EKG/ONZ 55.01: **E20-55R-01 1399**

Certificate no. : **B/1/199/2000**

Foreword

This towbar is design according to rules of safety traffic regulations. The towing hitch is a safety component and must be installed only by qualified personnel. Any alteration or conversion to the towinh hitch is prohibited and would lead to cancellation of design certification. Remove insulating compound and underseal from vehicle (if present) in the area of the matting surfaces of the towing hitch. The vehicle manufacturer's specifications regarding trailer load and max. vertical cup load are decisive for driving, and values for the towing hitch must not be exceeded.

D-value formula:

$$\frac{\text{Max trailer weight [kg]} \times \text{Max vehicle weight [kg]}}{\text{Max trailer weight [kg]} + \text{Max vehicle weight [kg]}} \times \frac{9,81}{1000} = D \text{ [kN]}$$